

The information in this document is subject to change without notice and should not be construed as a commitment by ABB. ABB assumes no responsibility for any errors that may appear in this document.

Except as may be expressly stated anywhere in this document, nothing herein shall be construed as any kind of guarantee or warranty by ABB for losses, damages to persons or property, fitness for a specific purpose or the like.

In no event shall ABB be liable for incidental or consequential damages arising from use of this document.

This document and parts thereof must not be reproduced or copied without ABB's written permission, and contents thereof must not be imparted to a third party nor be used for any unauthorized purpose. Contravention will be prosecuted.

Additional copies of this document may be obtained from ABB at its then current charge.

© Copyright 2019 ABB ALL right reserved.

ABB

SE-721 68 Västerås  
Sweden

Latest revision: ECO 105870 WI 241451 Pg 22(7): Functional earth added.		 Lab/Office: RARO SE RDM2	ROBOT CARRIER IRBT 4004/6004/7004 COPYRIGHT PAGE	Status: <b>APPROVED</b>	Plant: = Location: + Sublocation: +	Rev. Ind Page 1 <b>07</b> Next 2 Total 23
Prepared by, date: EM, 2018-08-15	Approved by, date: ML, 2018-08-21			Document no. <b>3HAC043574-001</b>		

we reserve all rights in this document and in the information contained therein. Reproduction, use or disclosure to third parties without express authority is strictly forbidden. © Copyright 2003 ABB





\*) SYSTEM CONFIGURATION

MOTOR No.	SMB NODE No.	UNIT
M7	7	IRBT SMB BOX A112

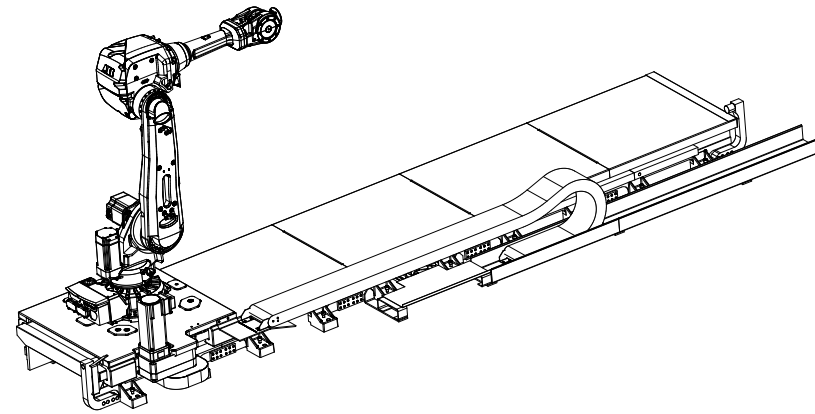

ON SINGLE CONTROLLER /  
DRIVE MODULE

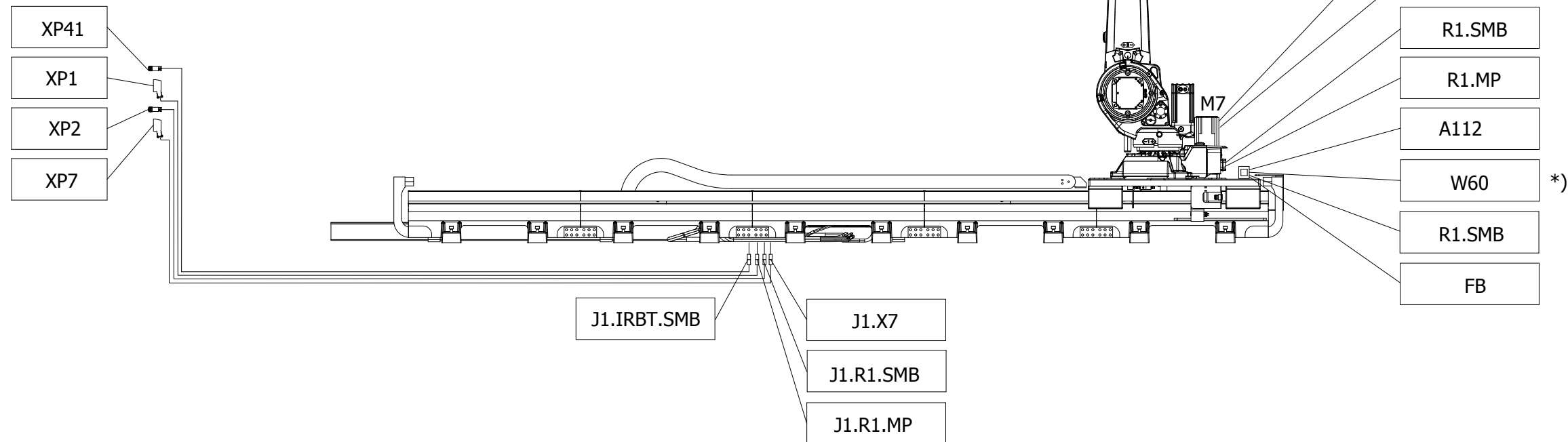

Latest revision:  
ECO 105870 WI 241451  
Pg 22(7): Functional earth added.

Prepared by, date: EM, 2018-08-15 | Approved by, date: ML, 2018-08-21



Lab/Office:  
RARO SE  
RDM2

ROBOT CARRIER IRBT 4004/6004/7004  
BLOCK DIAGRAM  
IRBT SMB BOX CONNECTION

Status:  
**APPROVED**

Document no.  
**3HAC043574-001**

Plant: =  
Location: +  
Sublocation: +

Rev. Ind Page 4  
**07** Next 5  
Total 23

we reserve all rights in this document and in the information contained therein. Reproduction, use or disclosure to third parties without express authority is strictly forbidden. © Copyright 2003 ABB

\*) SYSTEM CONFIGURATION

MOTOR No.	SMB NODE No.	UNIT
M7	7	IRB

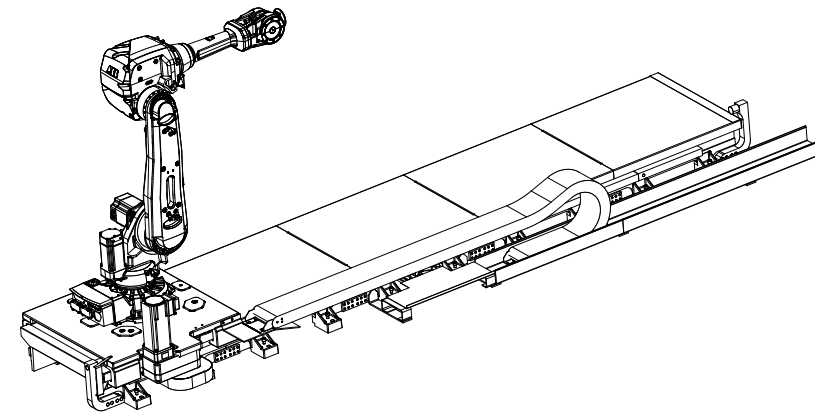

ON SINGLE CONTROLLER /  
DRIVE MODULE

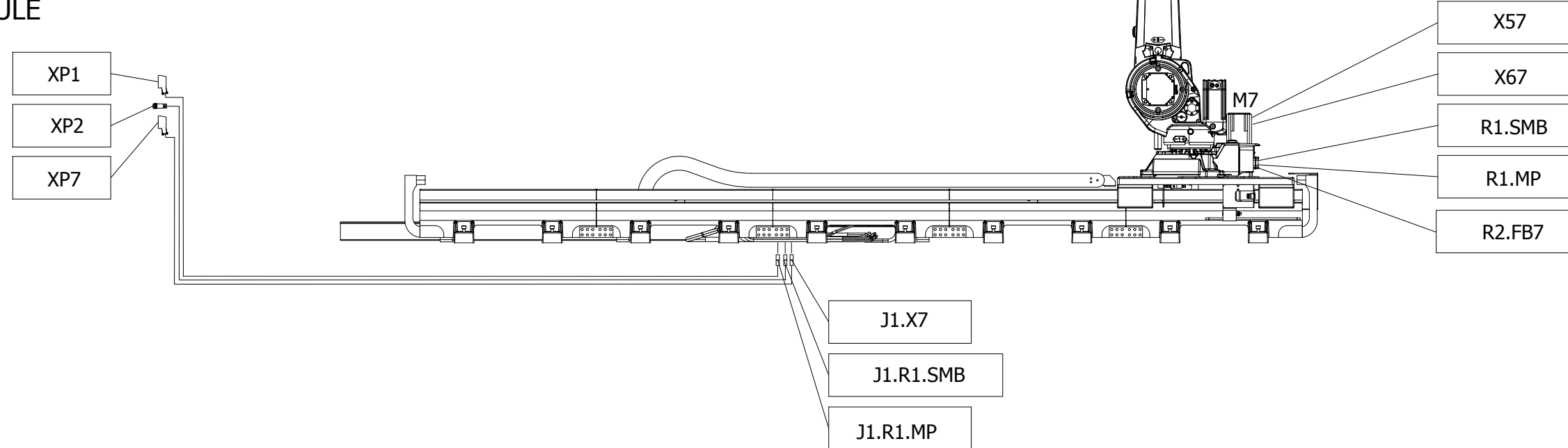

Latest revision:  
ECO 105870 WI 241451  
Pg 22(7): Functional earth added.

Prepared by, date: EM, 2018-08-15

Approved by, date: ML, 2018-08-21



Lab/Office:  
RARO SE  
RDM2

ROBOT CARRIER IRBT 4004/6004/7004  
BLOCK DIAGRAM  
IRB SMB CONNECTION

Status:  
APPROVED

Document no.

3HAC043574-001

Plant: =  
Location: +  
Sublocation: +

Rev. Ind

07

Page 5

Next 6

Total 23

SEE EL. DRAWINGS FOR THE  
ROBOT CONTROL SYSTEM

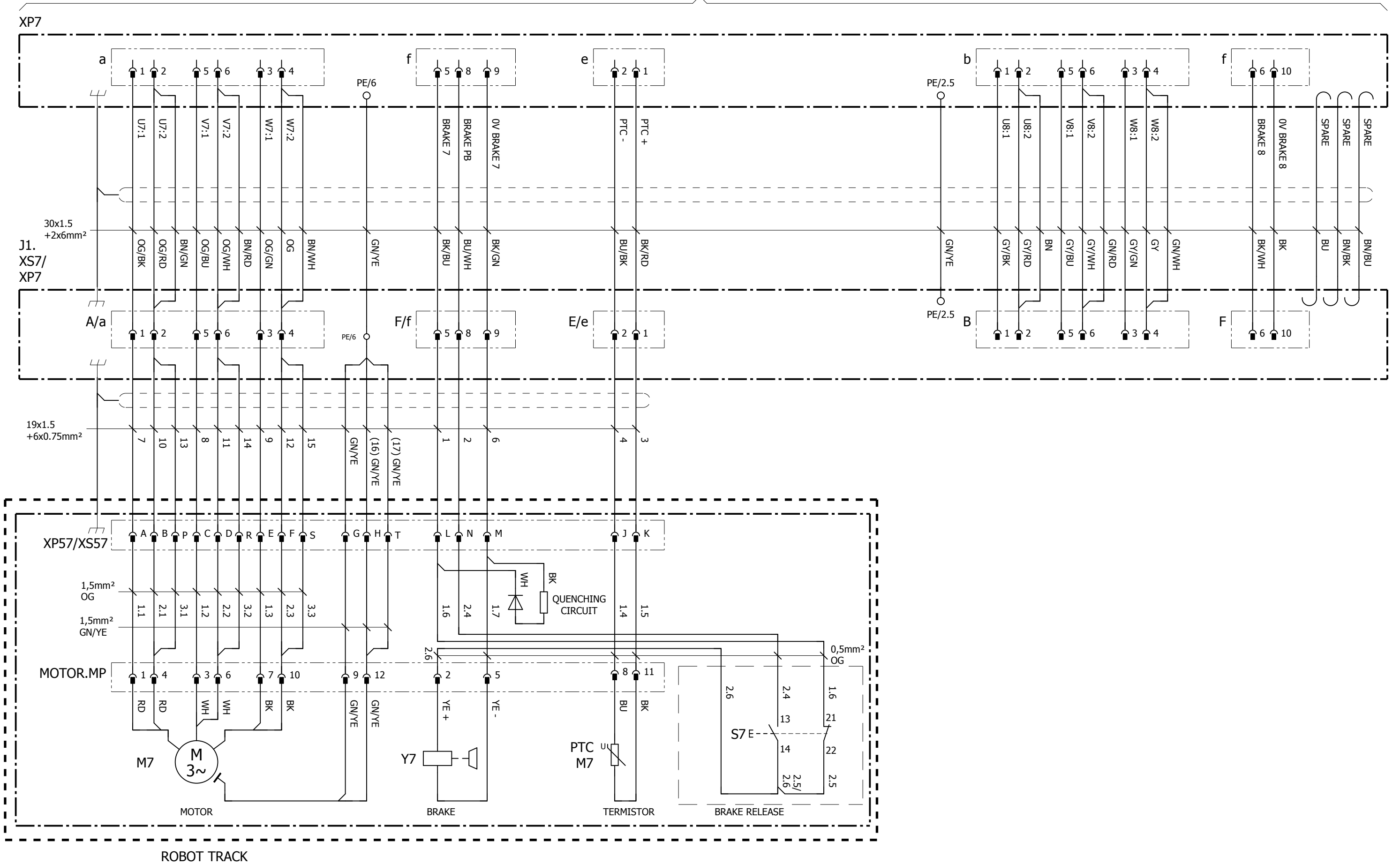

ROBOT TRACK

Latest revision:  
ECO 105870 WI 241451  
Pg 22(7): Functional earth added.

Prepared by, date: EM, 2018-08-15 | Approved by, date: ML, 2018-08-21



Lab/Office:  
RARO SE  
RDM2

ROBOT CARRIER IRBT 4004/6004/7004  
MOTOR IRBT, IRB2600/4400/4600/  
6xx0/7600

Status:  
**APPROVED**

Plant: =  
Location: +  
Sublocation: +

Document no.  
**3HAC043574-001**

Rev. Ind Page 6  
**07** Next 7  
Total 23

SEE EL. DRAWINGS FOR THE  
ROBOT CONTROL SYSTEM

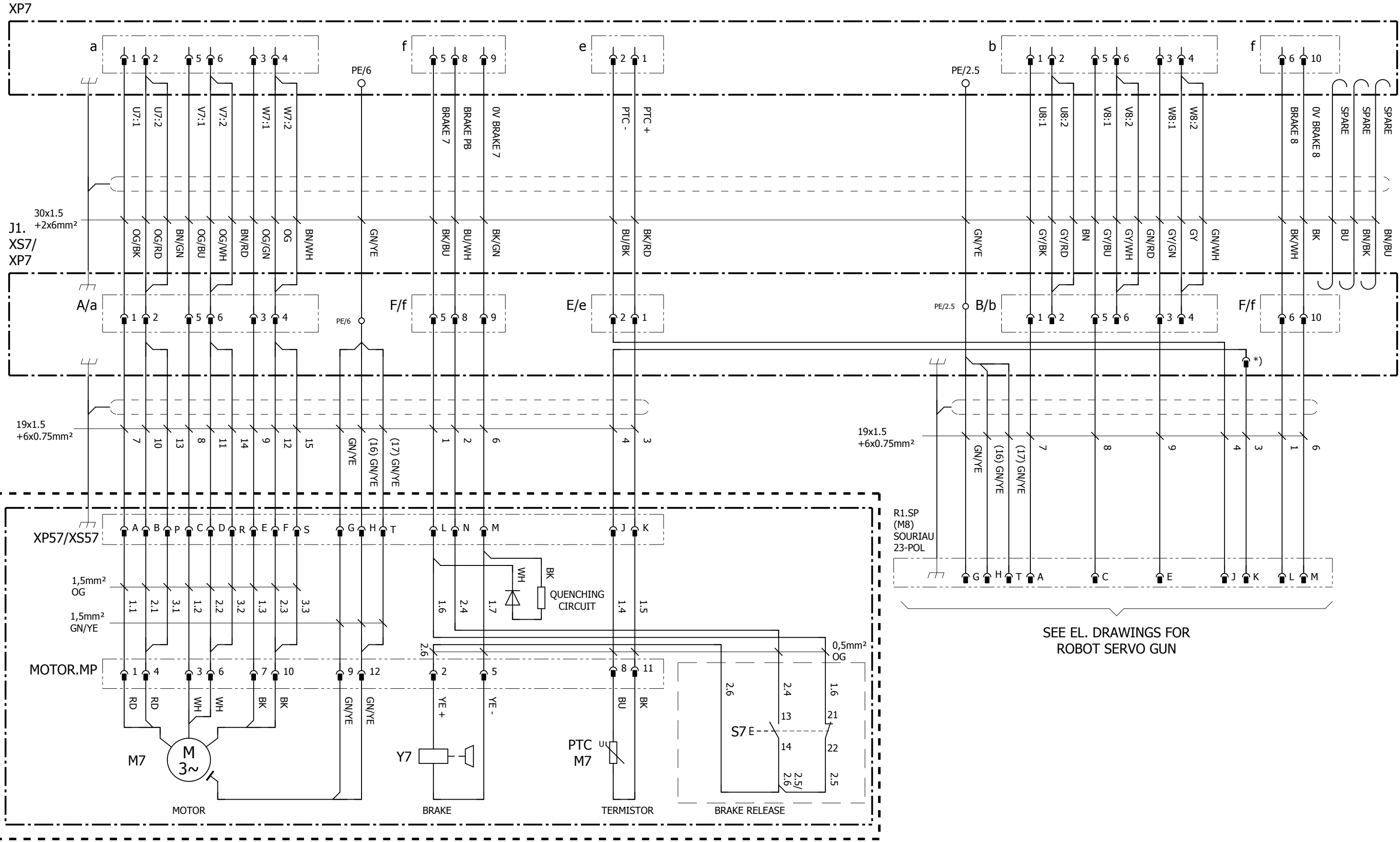

SEE EL. DRAWINGS FOR  
ROBOT SERVO GUN

ROBOT TRACK

\*) 1-POL CONNECTOR

Latest revision:  
ECO 105870 WI 241451  
Pg 22(7): Functional earth added.  
Prepared by, date: EM, 2018-08-15  
Approved by, date: ML, 2018-08-21



Lab/Office:  
RARO SE  
RDM2

ROBOT CARRIER IRBT 4004/6004/7004  
MOTOR IRBT, OPTION SERVO GUN  
IRB6xx0/IRB7600

Status:  
**APPROVED**

Plant: =  
Location: +  
Sublocation: +

Document no.  
**3HAC043574-001**  
Rev. Ind **07**  
Page 7  
Next 7.b  
Total 23

SEE EL. DRAWINGS FOR THE  
ROBOT CONTROL SYSTEM

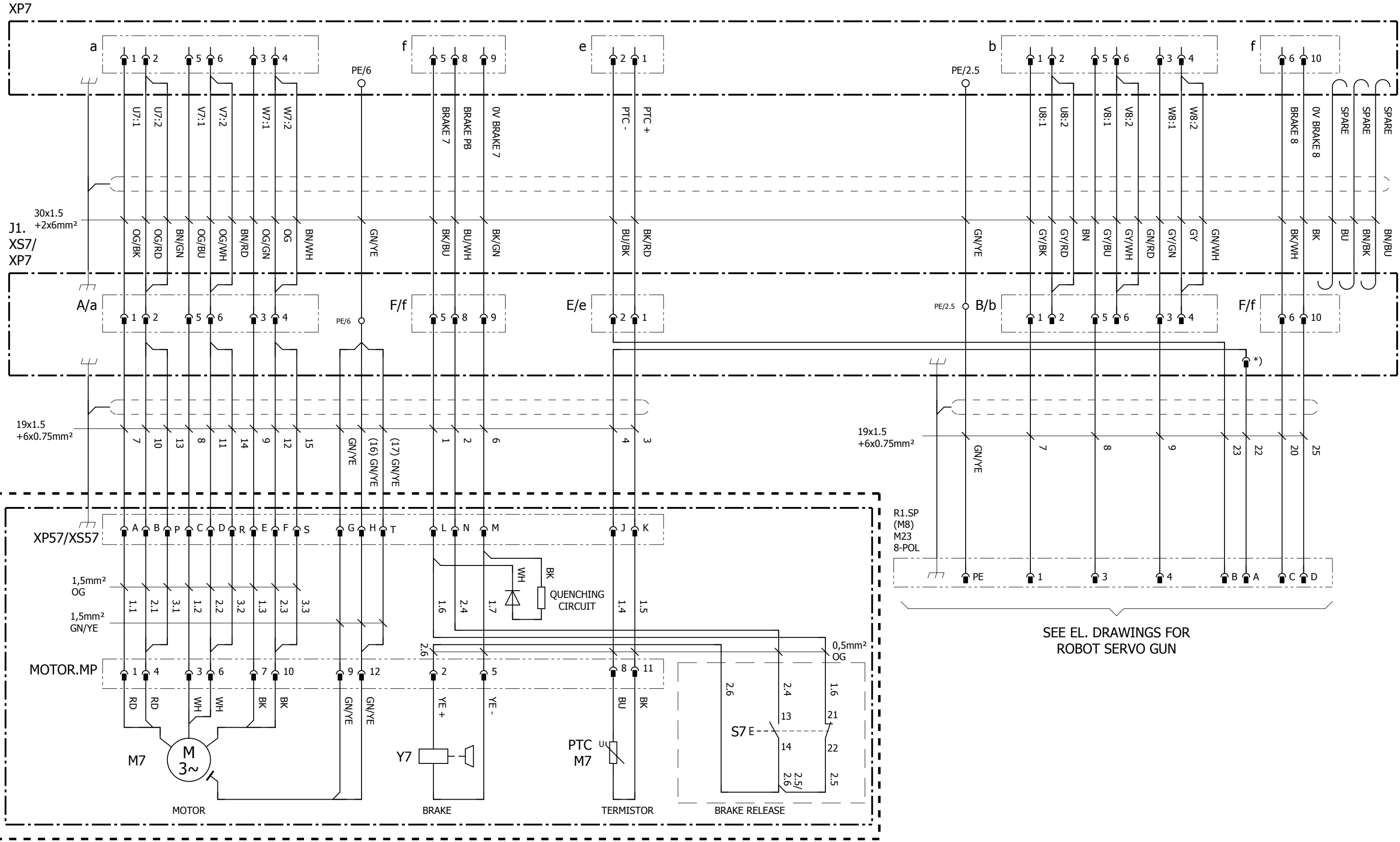

SEE EL. DRAWINGS FOR  
ROBOT SERVO GUN

ROBOT TRACK

\*) 1-POL CONNECTOR

Latest revision:  
ECO 105870 WI 241451  
Pg 22(7): Functional earth added.  
Prepared by, date: EM, 2018-08-15  
Approved by, date: ML, 2018-08-21

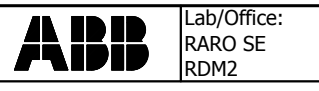

Lab/Office:  
RARO SE  
RDM2

ROBOT CARRIER IRBT 4004/6004/7004  
MOTOR IRBT, OPTION SERVO GUN  
IRB6xx0/IRB7600

Status:  
**APPROVED**

Plant: =  
Location: +  
Sublocation: +

Document no.  
**3HAC043574-001**  
Rev. Ind **07**  
Page 7.b  
Next 8  
Total 23



SEE EL. DRAWINGS FOR THE ROBOT CONTROL SYSTEM

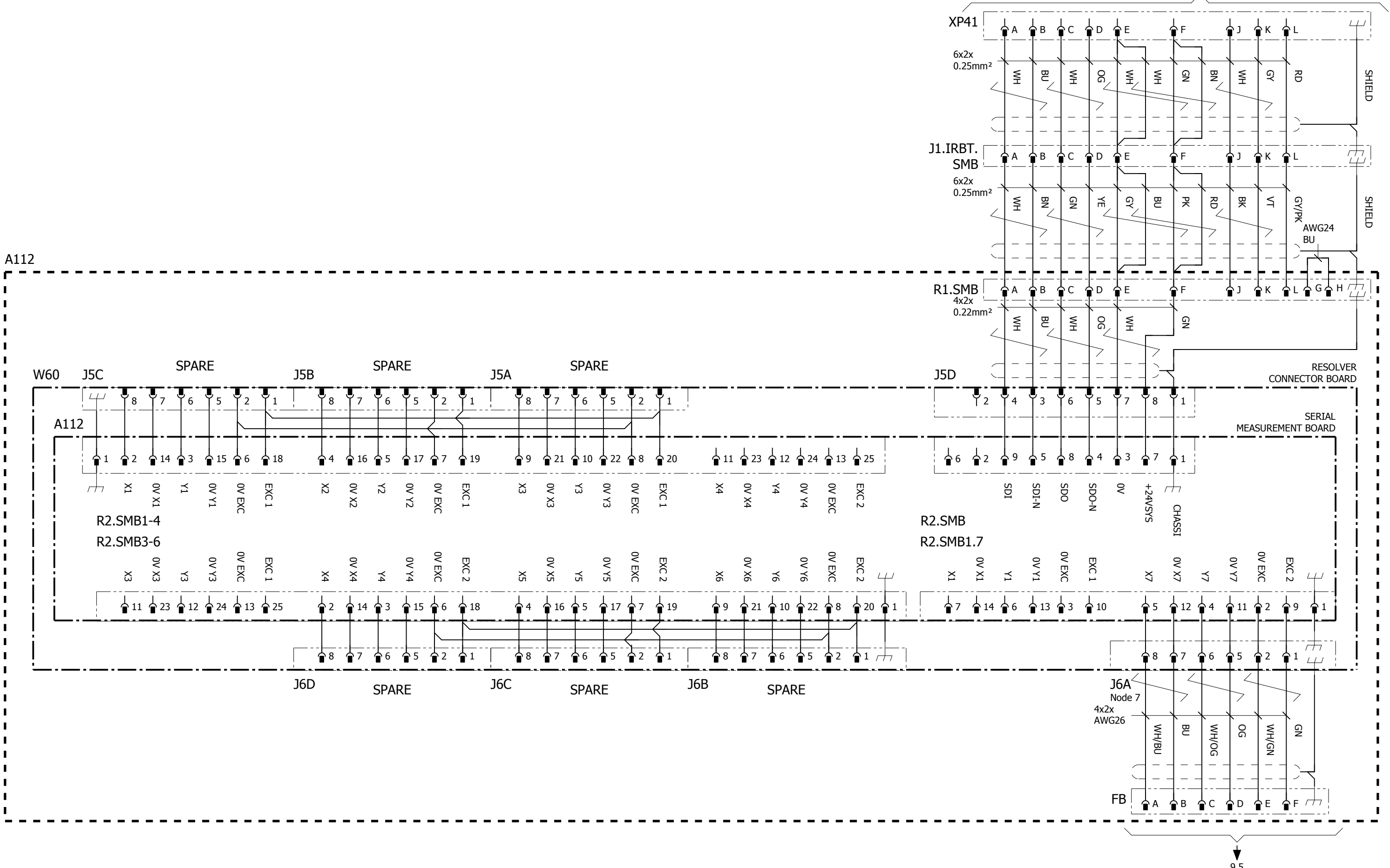

9.5

Latest revision:  
ECO 105870 WI 241451  
Pg 22(7): Functional earth added.

Prepared by, date: EM, 2018-08-15  
Approved by, date: ML, 2018-08-21

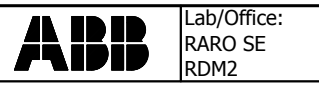

Lab/Office:  
RARO SE  
RDM2

ROBOT CARRIER IRBT 4004/6004/7004  
IRBT SMB BOX CONNECTION,  
IRB2600/4400/4600/6xx0/7600

Status:  
**APPROVED**

Document no.  
**3HAC043574-001**

Plant: =  
Location: +  
Sublocation: +

Rev. Ind Page 8  
**07** Next 9  
Total 23

8.8

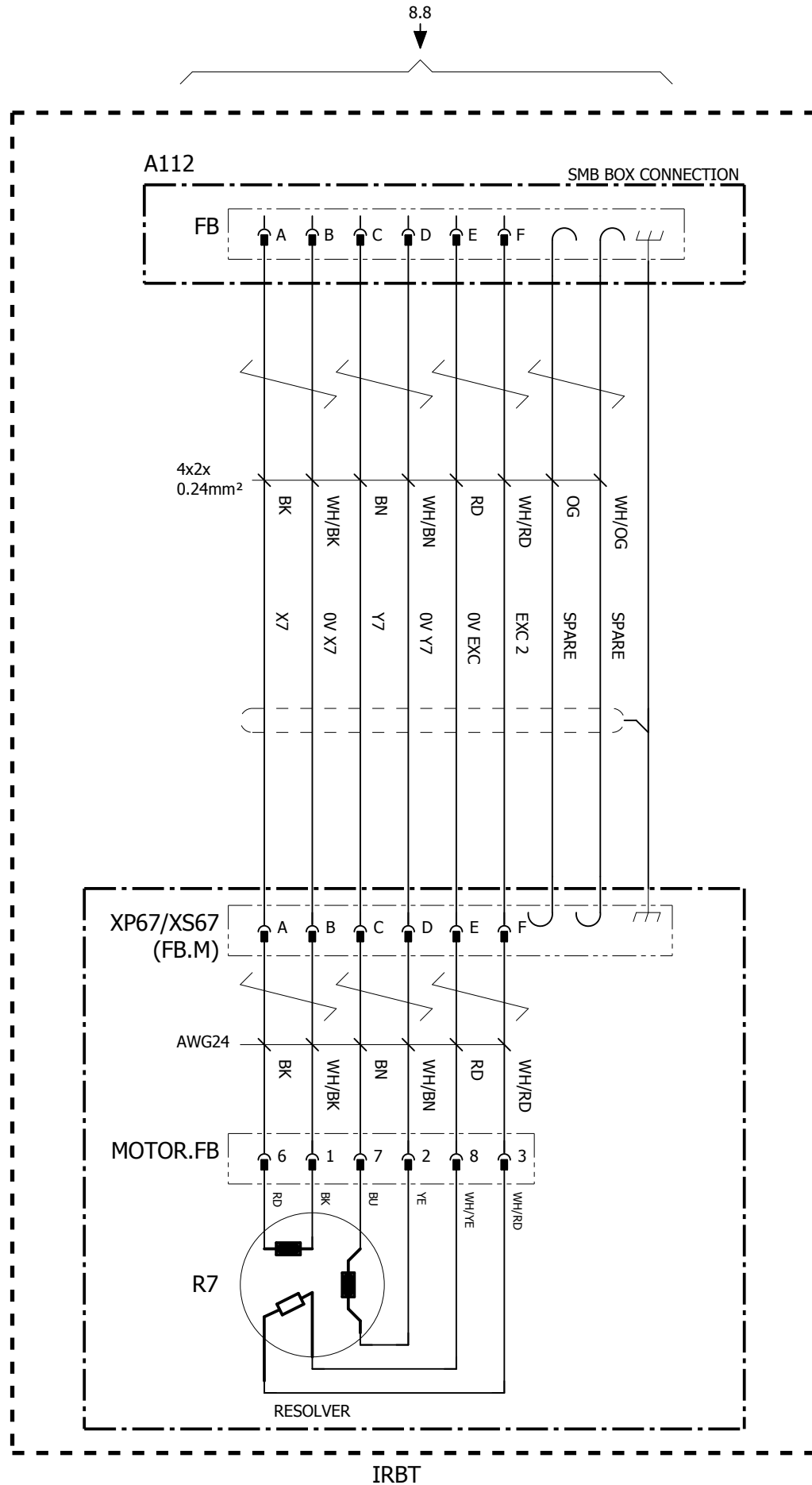

IRBT

Latest revision:  
 ECO 105870 WI 241451  
 Pg 22(7): Functional earth added.

Prepared by, date: EM, 2018-08-15 | Approved by, date: ML, 2018-08-21



Lab/Office:  
 RARO SE  
 RDM2

ROBOT CARRIER IRBT 4004/6004/7004  
 RESOLVER MOTOR IRBT, SMB BOX  
 CONN. IRB2600/4400/4600/6xx0/7600

Status: APPROVED  
 Document no. 3HAC043574-001  
 Rev. Ind 07  
 Page 9  
 Next 10  
 Total 23

Plant: =  
 Location: +  
 Sublocation: +

We reserve all rights in this document and in the information contained therein. Reproduction, use or disclosure to third parties without express authority is strictly forbidden. © Copyright 2003 ABB

SEE EL.DWGS FOR THE IRB  
MANIPULATOR

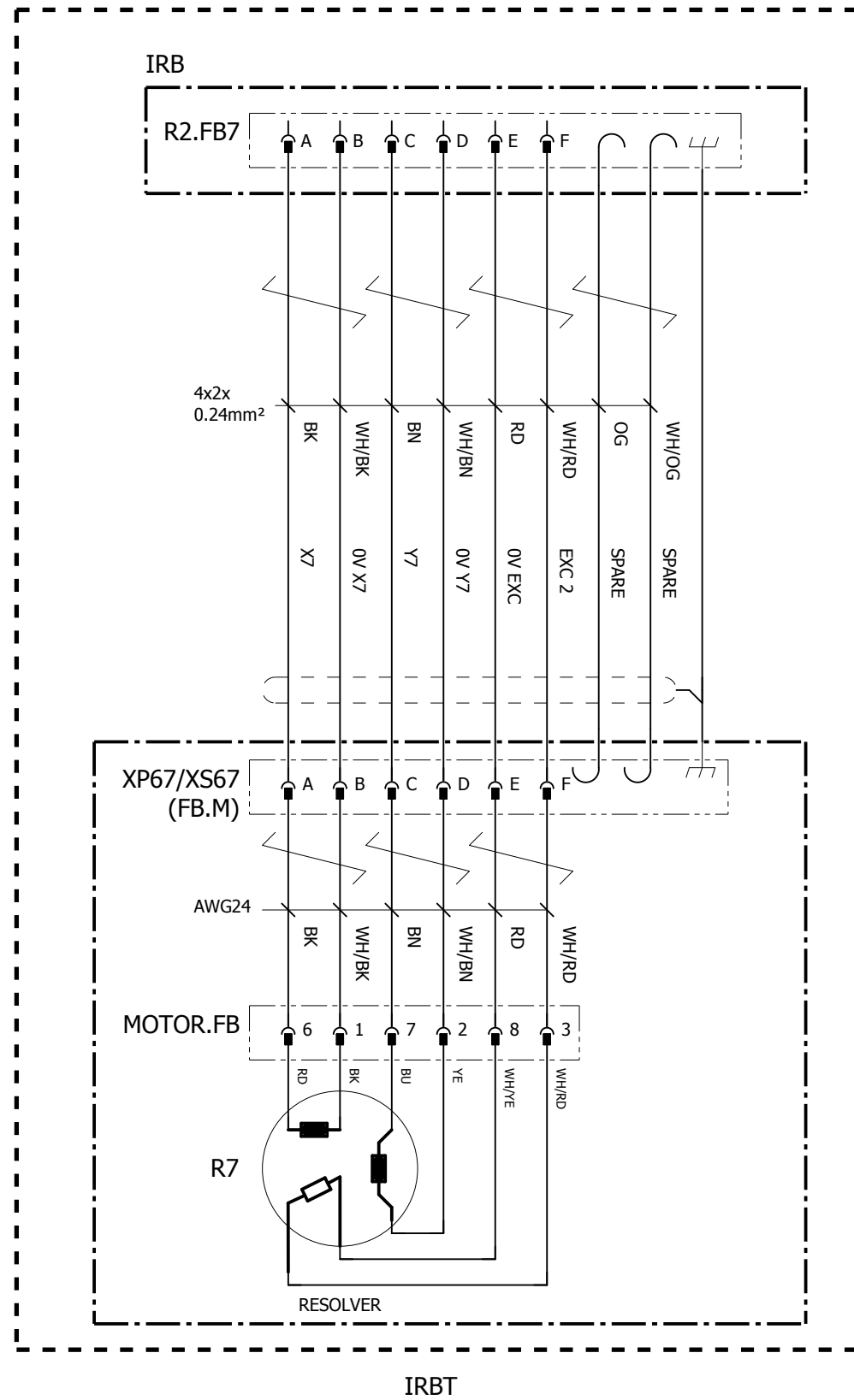

We reserve all rights in this document and in the information contained therein. Reproduction, use or disclosure to third parties without express authority is strictly forbidden. © Copyright 2003 ABB

Latest revision:  
ECO 105870 WI 241451  
Pg 22(7): Functional earth added.

Prepared by, date: EM, 2018-08-15      Approved by, date: ML, 2018-08-21



Lab/Office:  
RARO SE  
RDM2

ROBOT CARRIER IRBT 4004/6004/7004  
RESOLVER MOTOR IRBT, IRB SMB  
CONN. IRB2600/4400/4600/6xx0/7600

Status:  
**APPROVED**

Plant: =  
Location: +  
Sublocation: +

Document no.  
**3HAC043574-001**

Rev. Ind **07**      Page 10  
Next 11  
Total 23

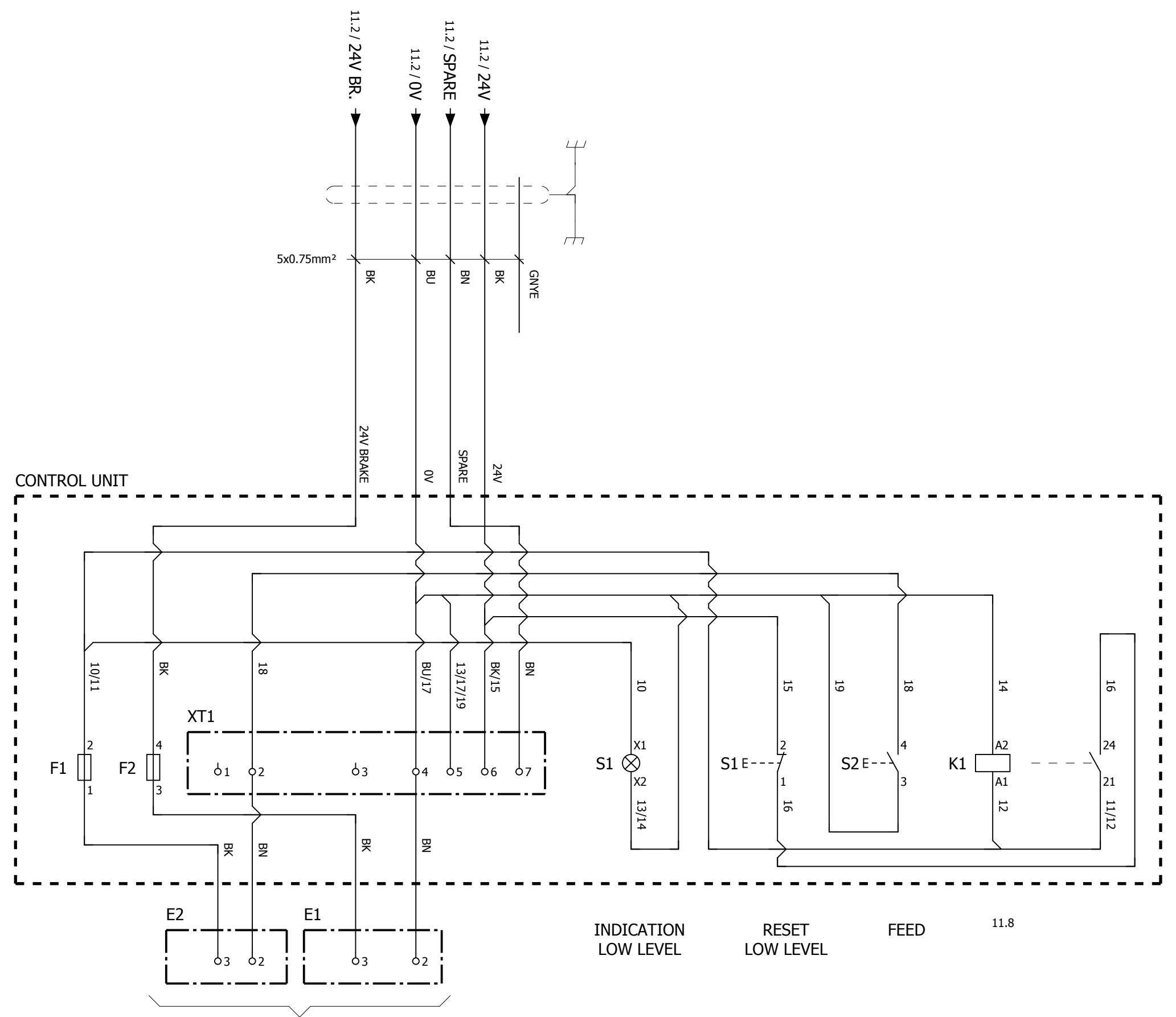
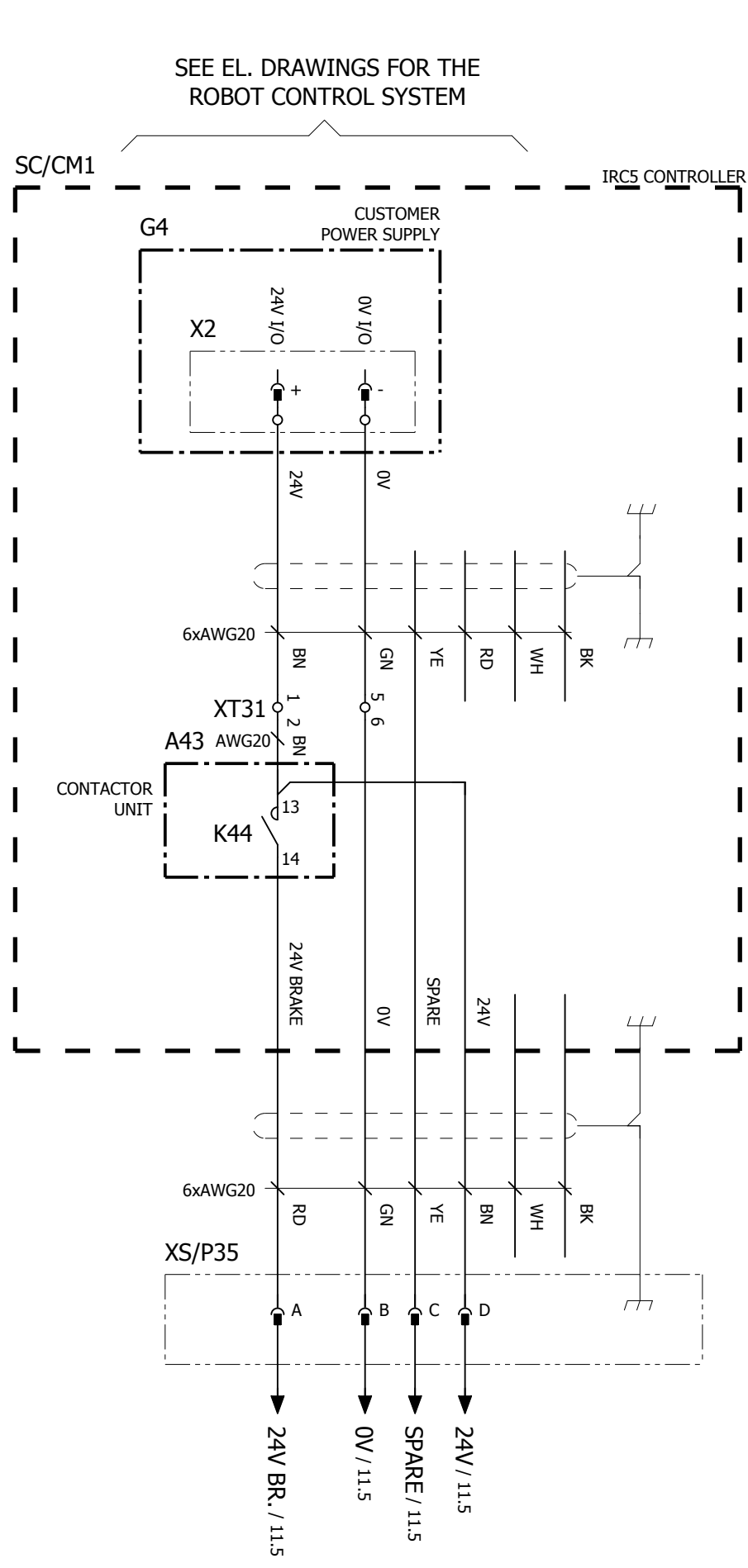

SEE EL. DRAWINGS FOR LUBRICATION PUMP UNIT

CONNECTED WITH AWG 20 BU, IF NO OTHER NOTATION

Latest revision:  
ECO 105870 WI 241451  
Pg 22(7): Functional earth added.

Prepared by, date: EM, 2018-08-15  
Approved by, date: ML, 2018-08-21

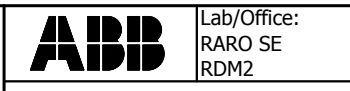

ROBOT CARRIER IRBT 4004/6004/7004  
OPTION LUBRICATION IRBT

Status: APPROVED  
Document no. 3HAC043574-001  
Rev. Ind 07  
Page 11  
Next 12  
Total 23

Plant: =  
Location: +  
Sublocation: +

SEE EL. DRAWINGS FOR THE  
ROBOT CONTROL SYSTEM

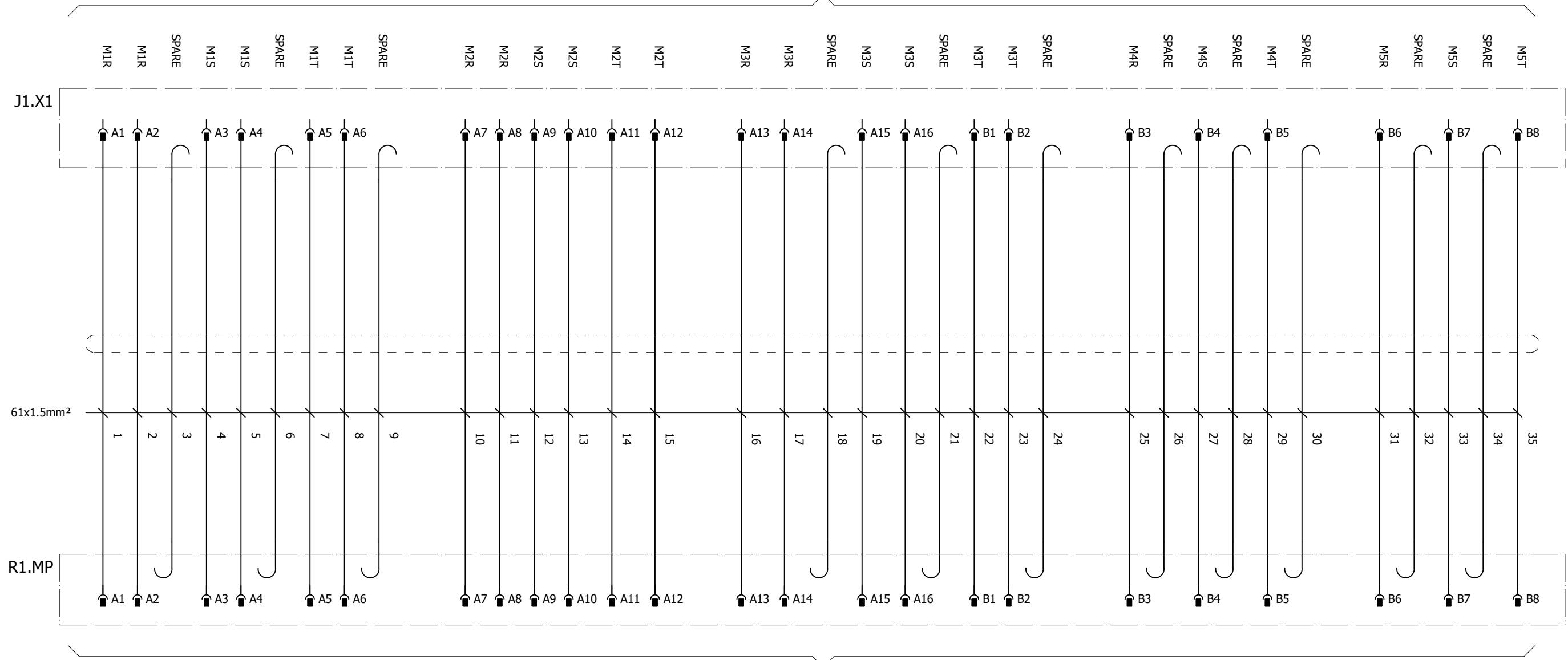

SEE EL. DRAWINGS FOR THE IRB MANIPULATOR

we reserve all rights in this document and in the information contained therein. Reproduction, use or disclosure to third parties without express authority is strictly forbidden. © Copyright 2003 ABB

Latest revision:  
ECO 105870 WI 241451  
Pg 22(7): Functional earth added.

Prepared by, date: EM, 2018-08-15      Approved by, date: ML, 2018-08-21

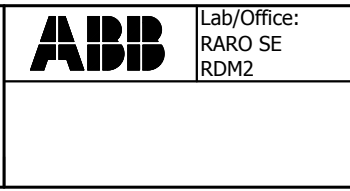

ROBOT CARRIER IRBT 4004/6004/7004  
MOTOR CABLE, IRB4400

Status: **APPROVED**

Plant: =  
Location: +  
Sublocation: +

Document no. **3HAC043574-001**

Rev. Ind **07**

Page 12  
Next 13  
Total 23

SEE EL. DRAWINGS FOR THE  
ROBOT CONTROL SYSTEM

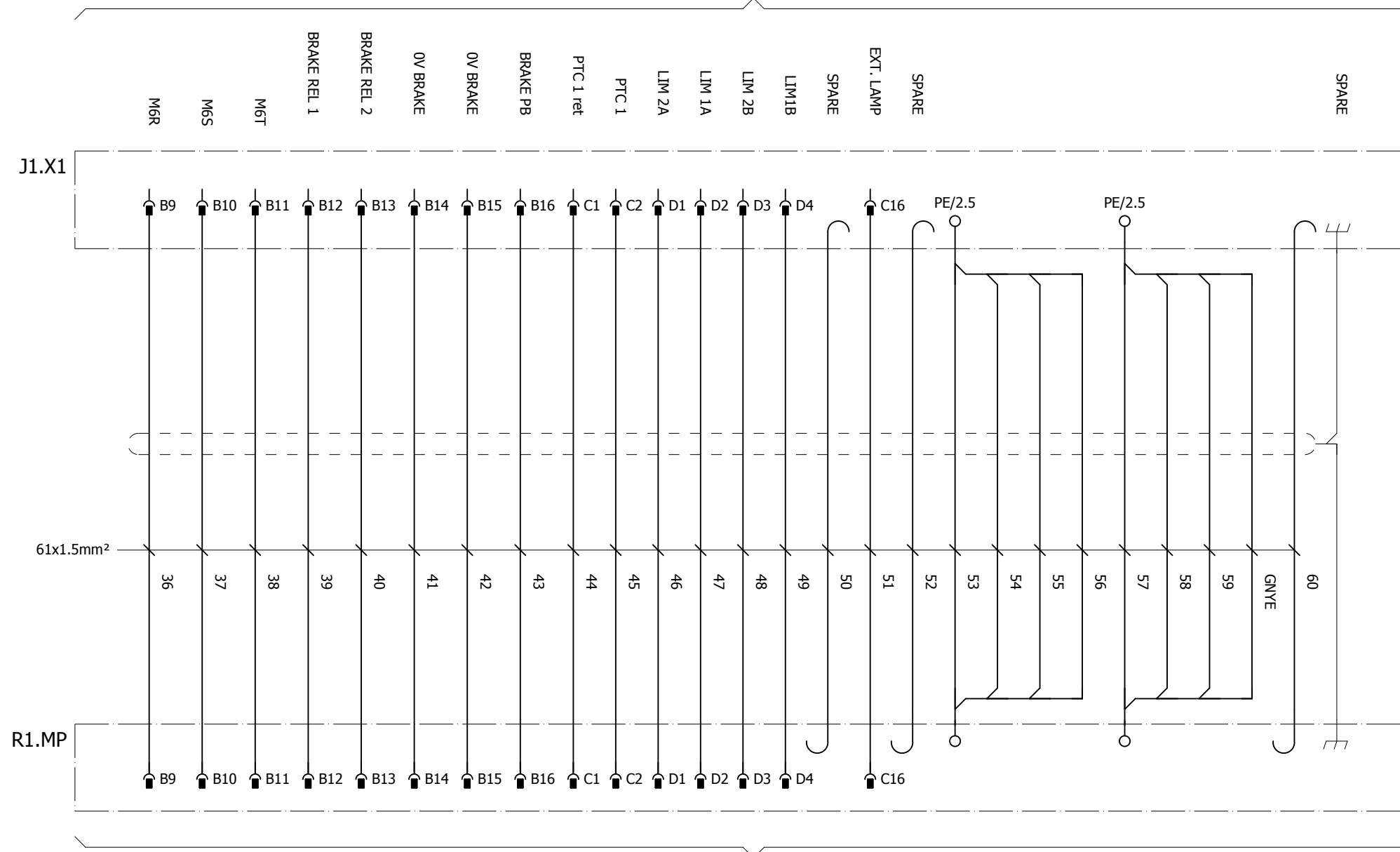

SEE EL. DRAWINGS FOR THE IRB MANIPULATOR

We reserve all rights in this document and in the information contained therein. Reproduction, use or disclosure to third parties without express authority is strictly forbidden. © Copyright 2003 ABB

Latest revision:  
ECO 105870 WI 241451  
Pg 22(7): Functional earth added.

Prepared by, date: EM, 2018-08-15 | Approved by, date: ML, 2018-08-21

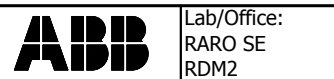

Lab/Office:  
RARO SE  
RDM2

ROBOT CARRIER IRBT 4004/6004/7004  
MOTOR CABLE, IRB4400

Status: <b>APPROVED</b>	Plant: = Location: + Sublocation: +
Document no. <b>3HAC043574-001</b>	Rev. Ind <b>07</b>
	Page 13 Next 14 Total 23

SEE EL. DRAWINGS FOR THE  
ROBOT CONTROL SYSTEM

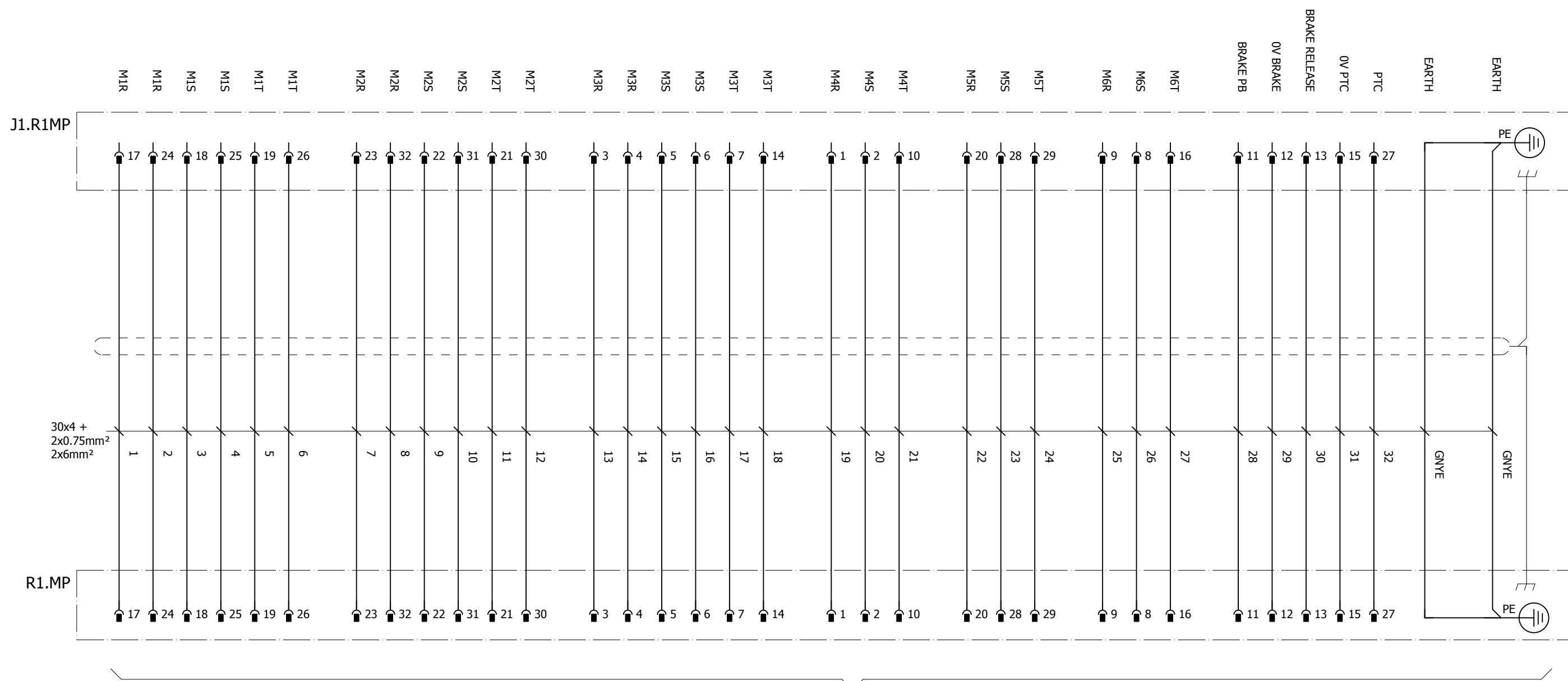

SEE EL. DRAWINGS FOR THE  
IRB MANIPULATOR

Latest revision:  
ECO 105870 WI 241451  
Pg 22(7): Functional earth added.

Prepared by, date: EM, 2018-08-15      Approved by, date: ML, 2018-08-21

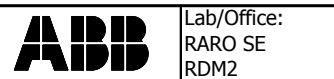

Lab/Office:  
RARO SE  
RDM2

ROBOT CARRIER IRBT 4004/6004/7004  
MOTOR CABLE, IRB2600/4600/6xx0/  
7600

Status:  
**APPROVED**

Plant: =  
Location: +  
Sublocation: +

Document no.  
**3HAC043574-001**

Rev. Ind **07**      Page 14  
Next 15  
Total 23

We reserve all rights in this document and in the information contained therein. Reproduction, use or disclosure to third parties without express authority is strictly forbidden. © Copyright 2003 ABB

SEE EL. DRAWINGS FOR THE ROBOT CONTROL SYSTEM

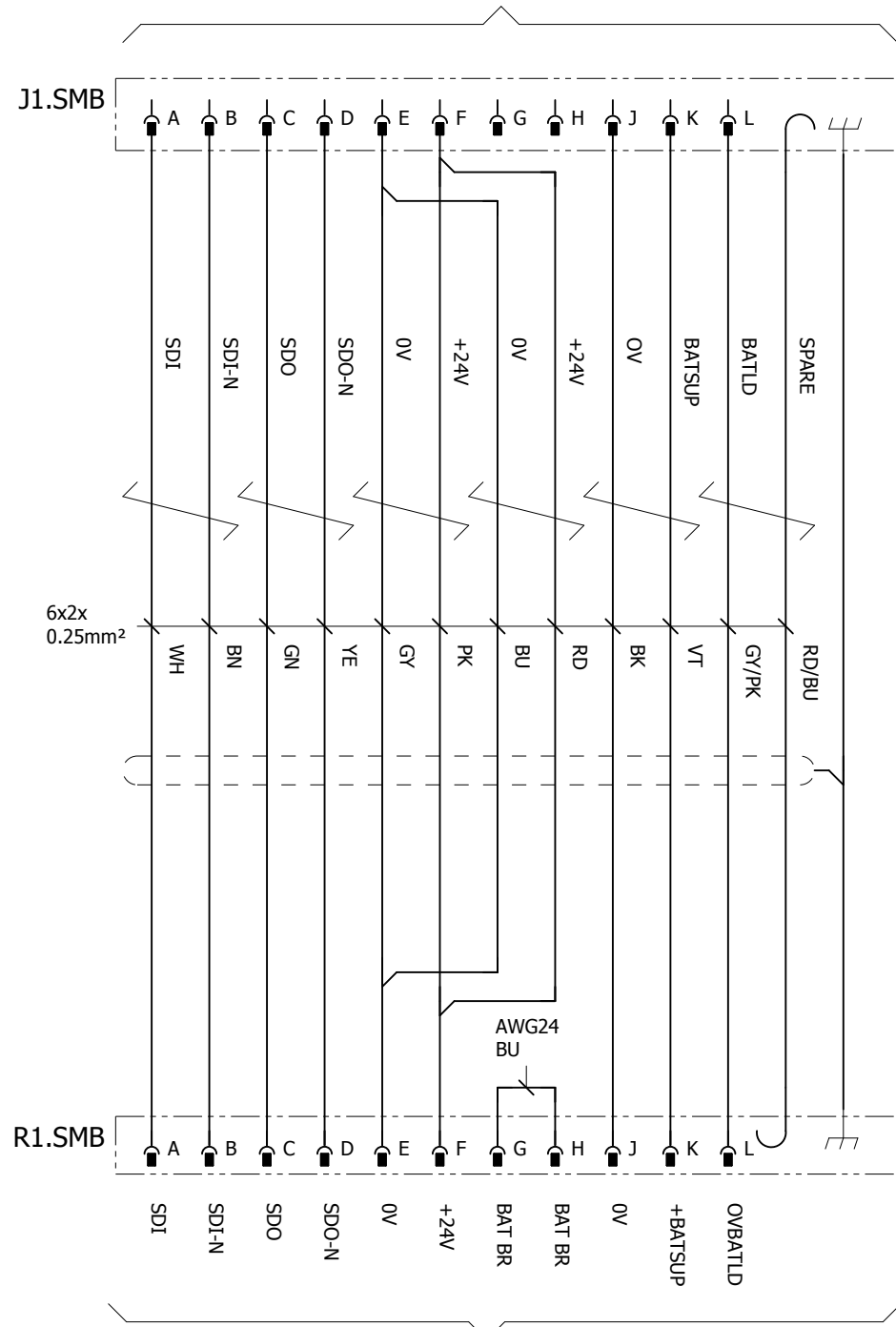

SEE EL.DWGS FOR THE IRB MANIPULATOR

Latest revision:  
 ECO 105870 WI 241451  
 Pg 22(7): Functional earth added.

Prepared by, date: EM, 2018-08-15 | Approved by, date: ML, 2018-08-21



Lab/Office:  
RARO SE  
RDM2

ROBOT CARRIER IRBT 4004/6004/7004  
 RESOLVER CABLE, IRB2600/4400/4600/  
 6xx0/7600

Status:  
APPROVED

Plant: =  
 Location: +  
 Sublocation: +

Document no.  
**3HAC043574-001**

Rev. Ind  
**07**

Page 15  
 Next 16  
 Total 23



SEE EL. DRAWINGS FOR THE  
ROBOT CONTROL SYSTEM

J1.CP/CS

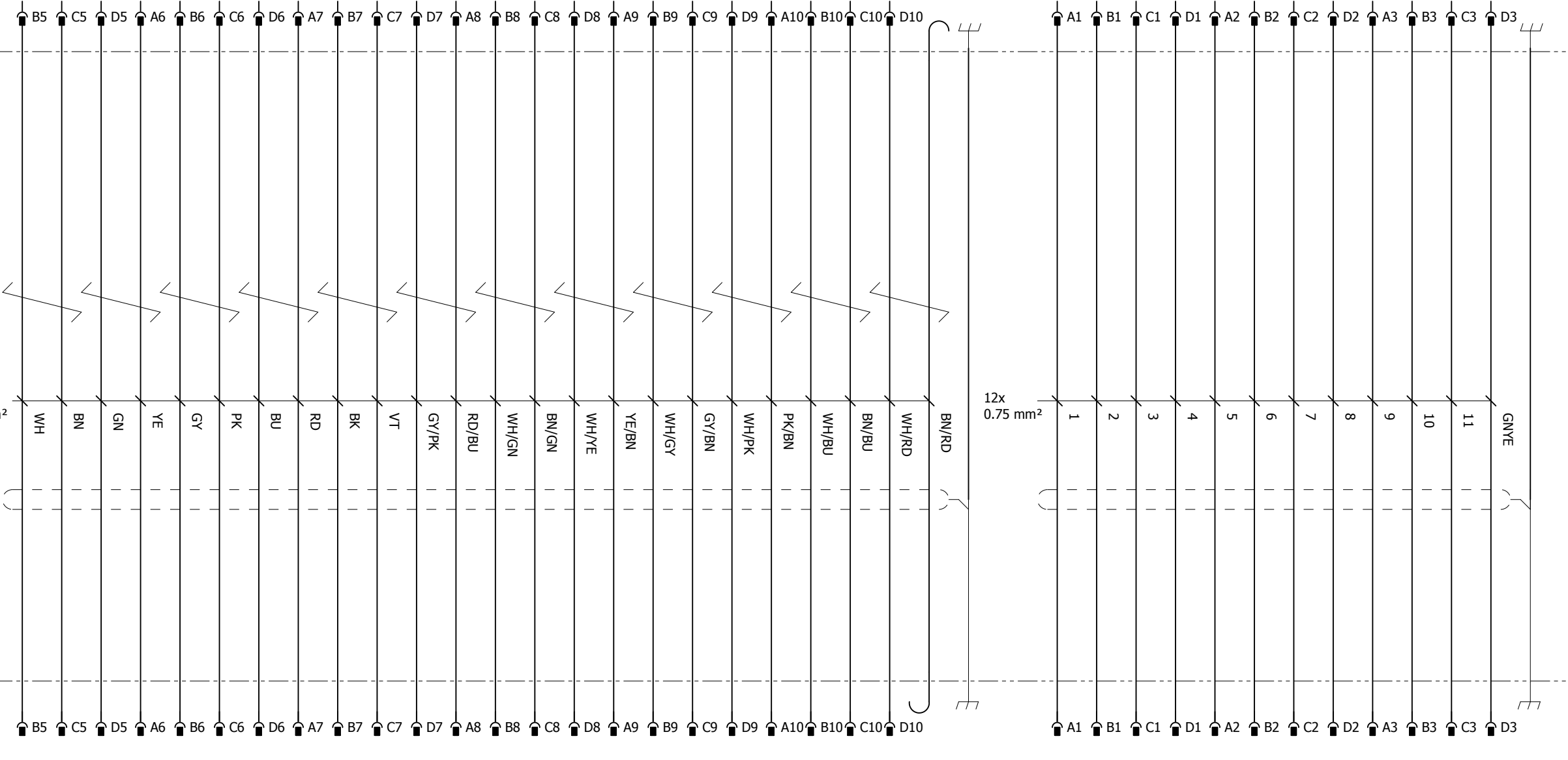

SEE EL. DRAWINGS FOR THE  
IRB MANIPULATOR

Latest revision:  
ECO 105870 WI 241451  
Pg 22(7): Functional earth added.

Prepared by, date: EM, 2018-08-15  
Approved by, date: ML, 2018-08-21

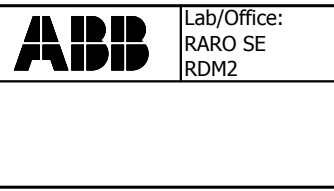

ROBOT CARRIER IRBT 4004/6004/7004  
OPTION CUSTOMER POWER/SIGNAL,  
IRB4400

Status: APPROVED  
Document no. 3HAC043574-001  
Rev. Ind 07  
Page 16  
Next 17  
Total 23

Plant: =  
Location: +  
Sublocation: +

We reserve all rights in this document and in the information contained therein. Reproduction, use or disclosure to third parties without express authority is strictly forbidden. © Copyright 2003 ABB

SEE EL. DRAWINGS FOR THE  
ROBOT CONTROL SYSTEM

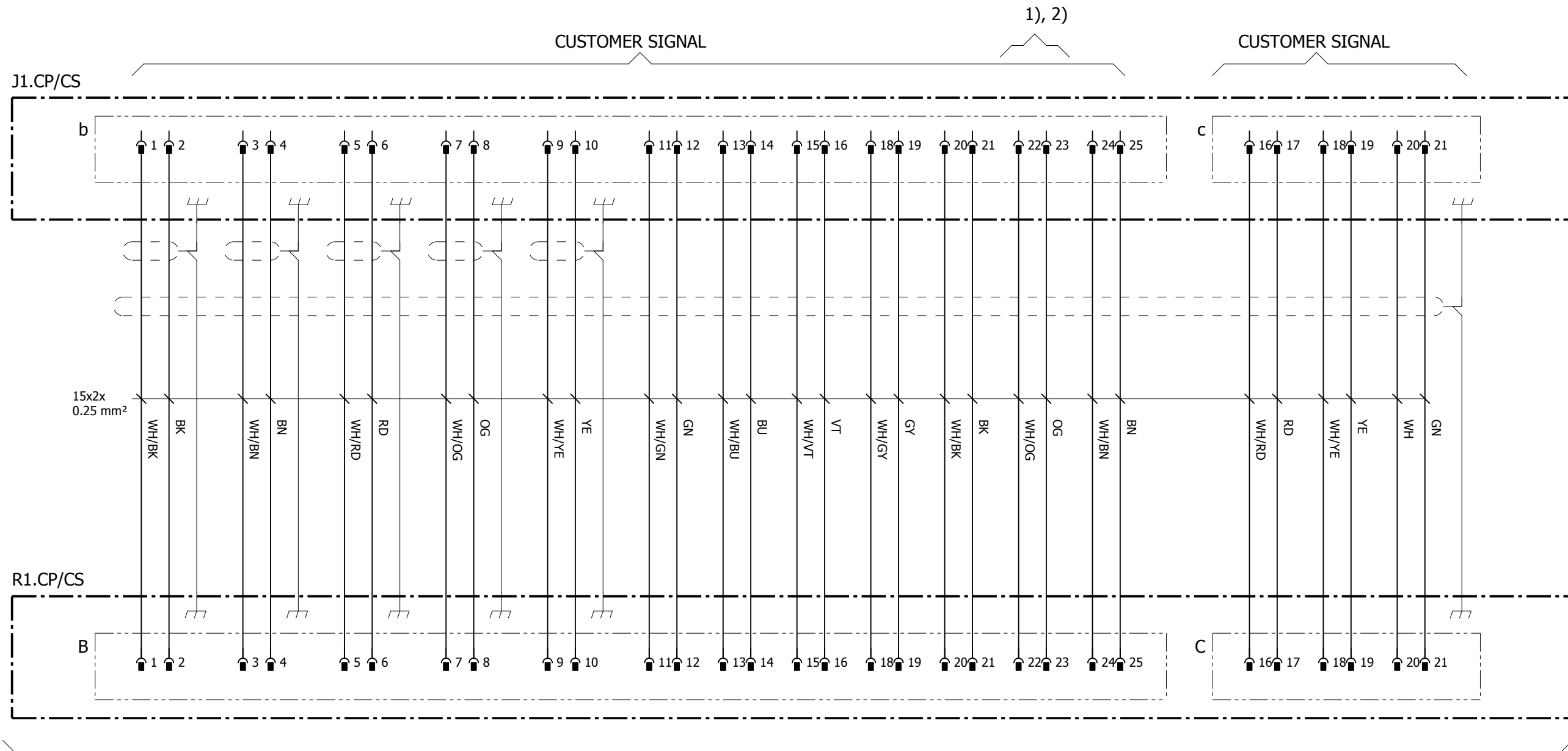

SEE EL. DRAWINGS FOR THE  
IRB MANIPULATOR

- 1) Part OG, WH/OG not connected to b/B.22,23 when Opt. DeviceNet, see sh. 18.
- 2) Part WH/OG not connected to b/B.22 when Opt. Interbus, see sh. 19.

Latest revision:  
ECO 105870 WI 241451  
Pg 22(7): Functional earth added.

Prepared by, date: EM, 2018-08-15  
Approved by, date: ML, 2018-08-21

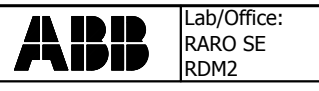

Lab/Office:  
RARO SE  
RDM2

ROBOT CARRIER IRBT 4004/6004/7004  
OPTION CUSTOMER POWER/SIGNAL,  
IRB2600/4600/6xx0/7600

Status: APPROVED  
Document no. 3HAC043574-001  
Rev. Ind 07

Plant: =  
Location: +  
Sublocation: +

Page 17  
Next 18  
Total 23

We reserve all rights in this document and in the information contained therein. Reproduction, use or disclosure to third parties without express authority is strictly forbidden. © Copyright 2003 ABB

SEE EL. DRAWINGS FOR THE  
ROBOT CONTROL SYSTEM

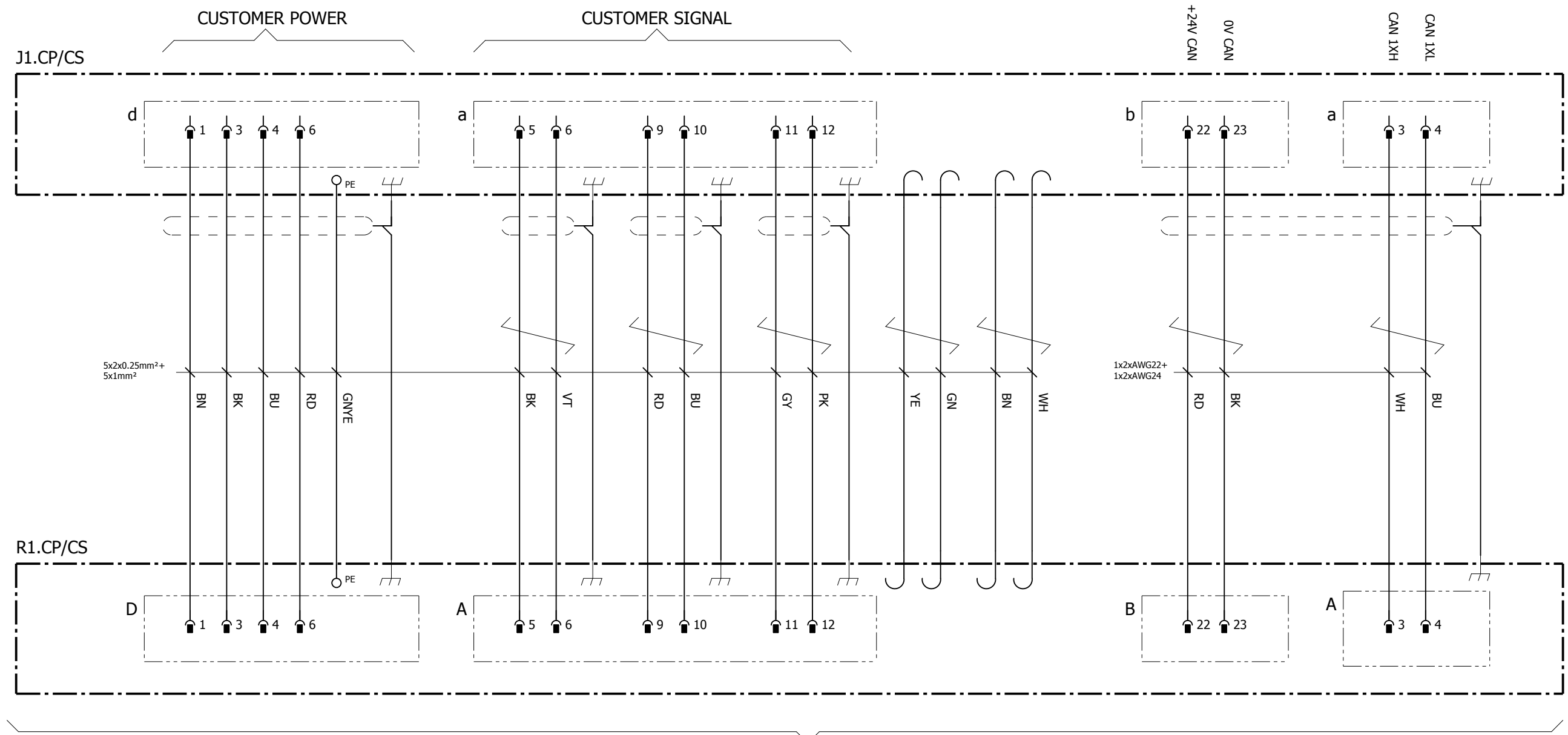

SEE EL. DRAWINGS FOR THE  
IRB MANIPULATOR

Latest revision:  
ECO 105870 WI 241451  
Pg 22(7): Functional earth added.

Prepared by, date: EM, 2018-08-15 | Approved by, date: ML, 2018-08-21



Lab/Office:  
RARO SE  
RDM2

ROBOT CARRIER IRBT 4004/6004/7004  
OPTION CUSTOMER POWER/SIGNAL  
DEVICENET, IRB2600/4600/6xx0/7600

Status: APPROVED  
Document no. 3HAC043574-001

Plant: =  
Location: +  
Sublocation: +

Rev. Ind 07 | Page 18  
Next 19  
Total 23

We reserve all rights in this document and in the information contained therein. Reproduction, use or disclosure to third parties without express authority is strictly forbidden. © Copyright 2003 ABB

SEE EL. DRAWINGS FOR THE  
ROBOT CONTROL SYSTEM

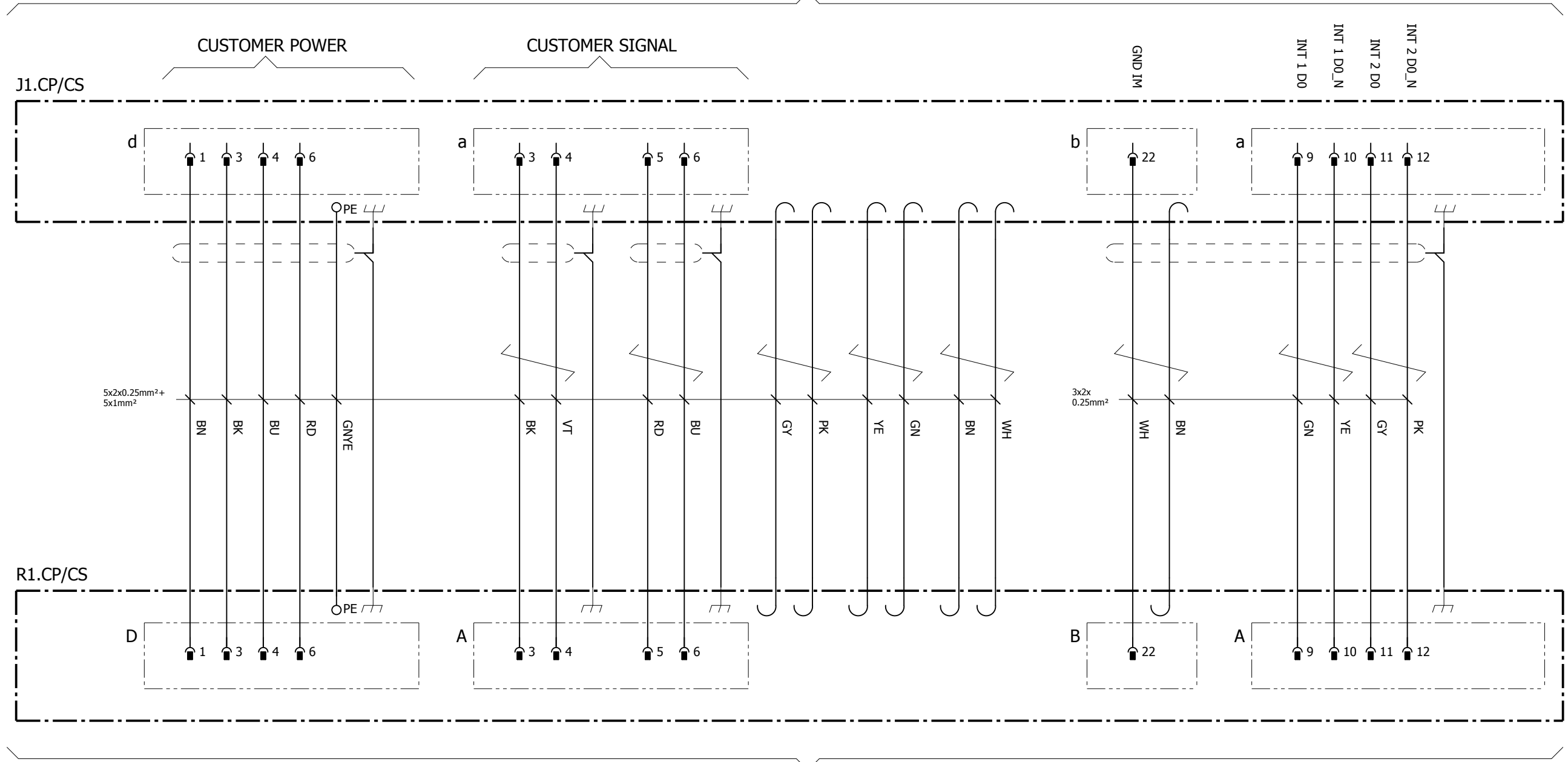

SEE EL. DRAWINGS FOR THE  
IRB MANIPULATOR

We reserve all rights in this document and in the information contained therein. Reproduction, use or disclosure to third parties without express authority is strictly forbidden. © Copyright 2003 ABB

Latest revision:  
ECO 105870 WI 241451  
Pg 22(7): Functional earth added.

Prepared by, date: EM, 2018-08-15      Approved by, date: ML, 2018-08-21

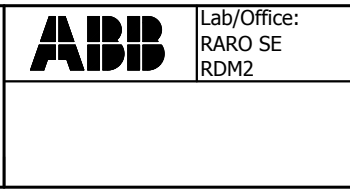

ROBOT CARRIER IRBT 4004/6004/7004  
OPTION CUSTOMER POWER/SIGNAL  
INTERBUS, IRB 6xx0/7600

Status: APPROVED  
Document no. 3HAC043574-001

Plant: =  
Location: +  
Sublocation: +

Rev. Ind 07      Page 19  
Next 20  
Total 23

SEE EL. DRAWINGS FOR THE  
ROBOT CONTROL SYSTEM

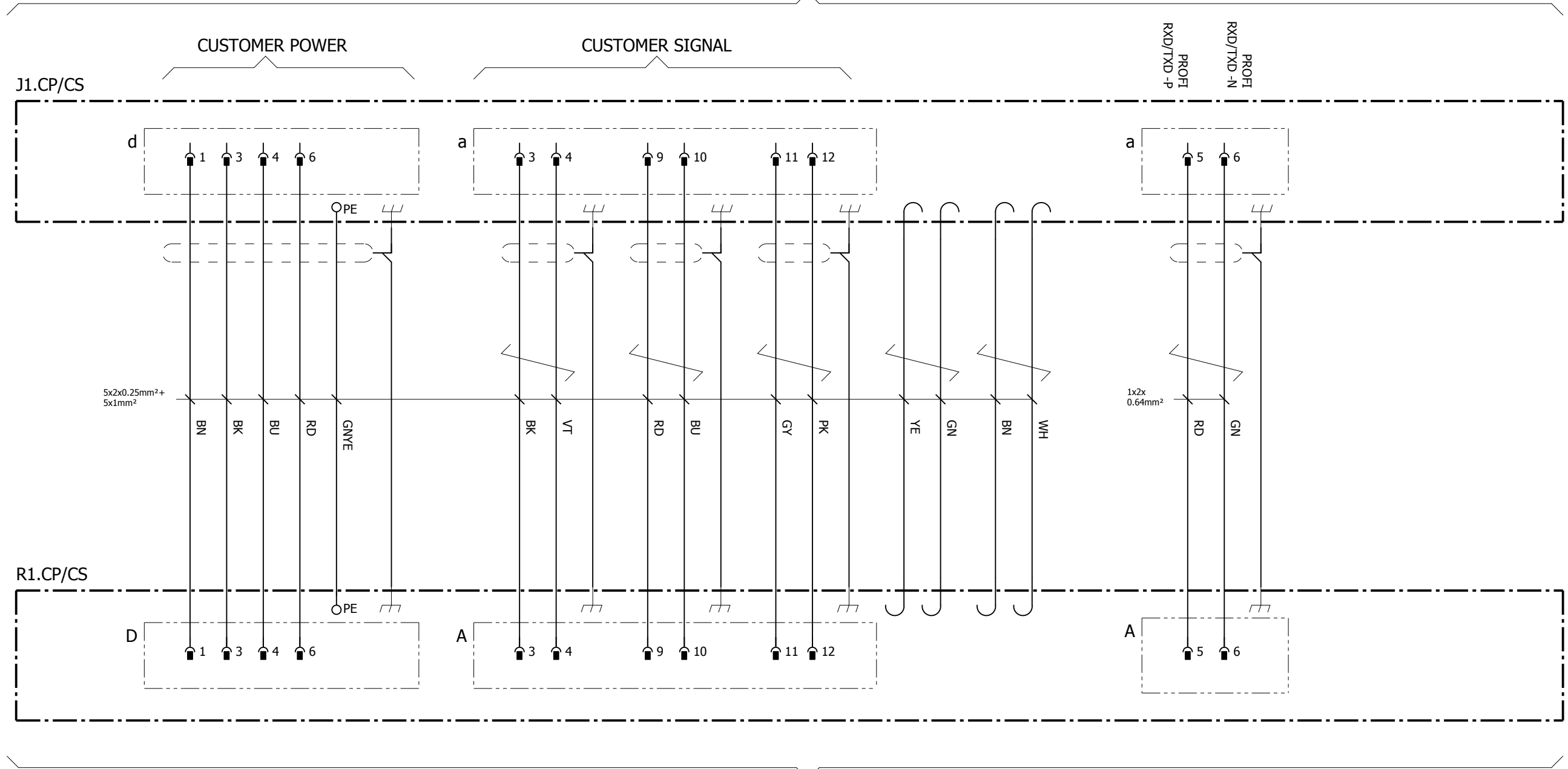

SEE EL. DRAWINGS FOR THE  
IRB MANIPULATOR

Latest revision:  
ECO 105870 WI 241451  
Pg 22(7): Functional earth added.

Prepared by, date: EM, 2018-08-15 | Approved by, date: ML, 2018-08-21



ROBOT CARRIER IRBT 4004/6004/7004  
OPTION CUSTOMER POWER/SIGNAL  
PROFIBUS, IRB 6xx0/7600

Status: APPROVED  
Document no. 3HAC043574-001

Plant: =  
Location: +  
Sublocation: +

Rev. Ind 07 | Page 20  
Next 21  
Total 23

We reserve all rights in this document and in the information contained therein. Reproduction, use or disclosure to third parties without express authority is strictly forbidden. © Copyright 2003 ABB

SEE EL. DRAWINGS FOR THE  
ROBOT CONTROL SYSTEM

CUSTOMER POWER

J1.CP/CS

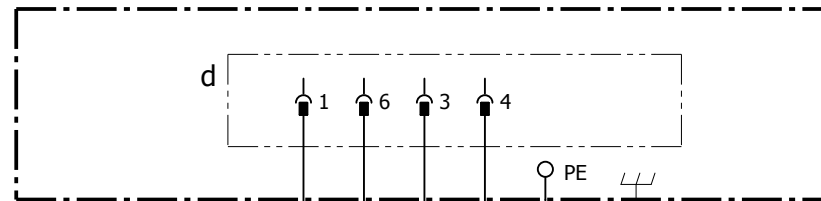

5x1 mm<sup>2</sup>

1 2 3 4 GND

R1.CP/CS

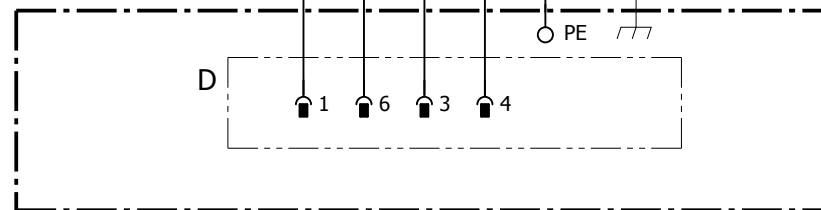

SEE EL. DRAWINGS FOR THE  
IRB MANIPULATOR

we reserve all rights in this document and in the information contained therein. Reproduction, use or disclosure to third parties without express authority is strictly forbidden. © Copyright 2003 ABB

Latest revision:  
ECO 105870 WI 241451  
Pg 22(7): Functional earth added.

Prepared by, date: EM, 2018-08-15 | Approved by, date: ML, 2018-08-21



Lab/Office:  
RARO SE  
RDM2

ROBOT CARRIER IRBT 4004/6004/7004  
OPTION CUSTOMER POWER/SIGNAL  
PARALLEL, IRB2600/4600/6xx0/7600

Status:  
**APPROVED**

Plant: =  
Location: +  
Sublocation: +

Document no.  
**3HAC043574-001**

Rev. Ind **07** | Page 21  
Next 22  
Total 23

SEE EL. DRAWINGS FOR THE  
ROBOT CONTROL SYSTEM

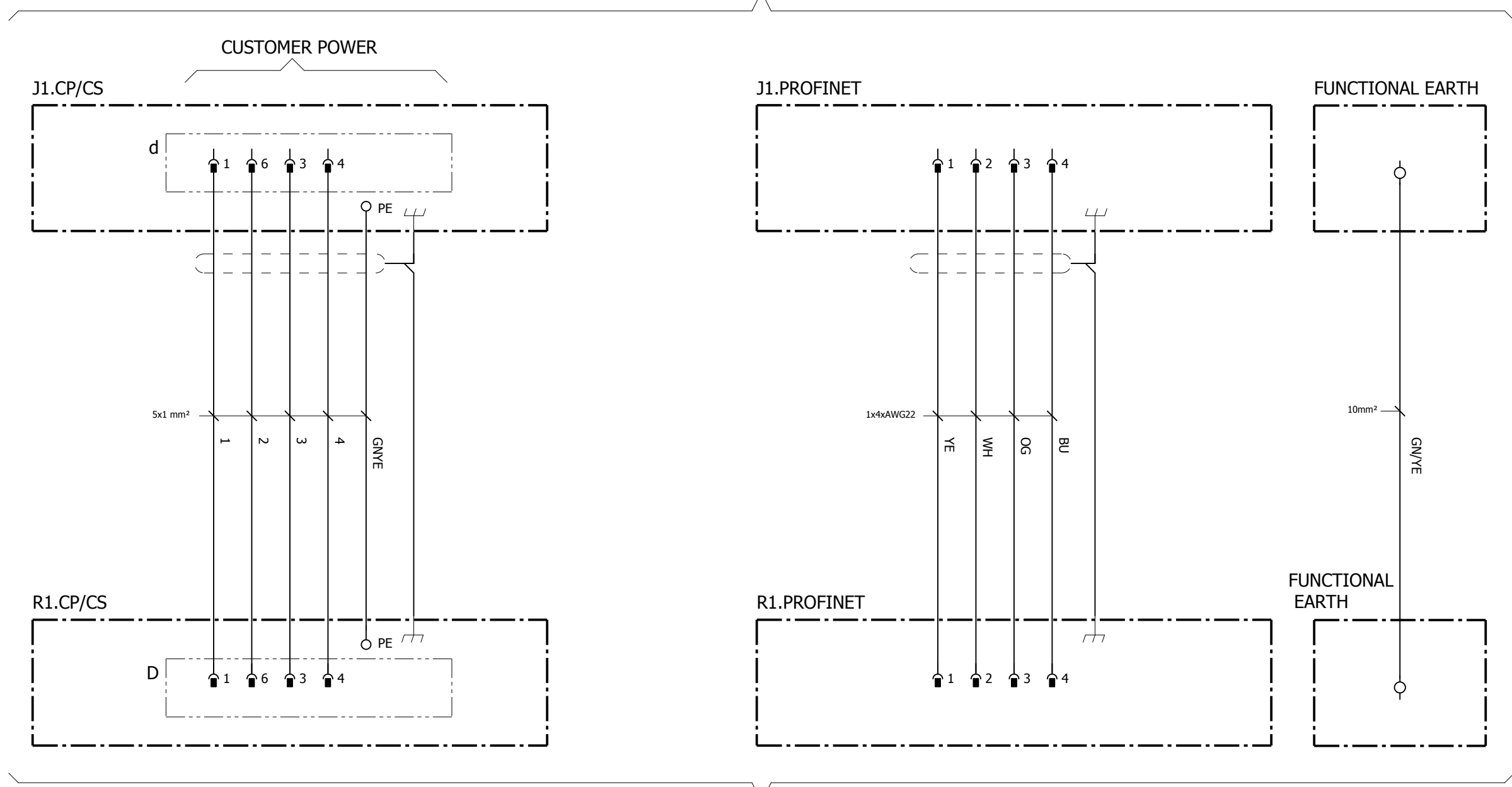

SEE EL. DRAWINGS FOR THE  
IRB MANIPULATOR

We reserve all rights in this document and in the information contained therein. Reproduction, use or disclosure to third parties without express authority is strictly forbidden. © Copyright 2003 ABB

Latest revision:  
ECO 105870 WI 241451  
Pg 22(7): Functional earth added.

Prepared by, date: EM, 2018-08-15      Approved by, date: ML, 2018-08-21



ROBOT CARRIER IRBT 4004/6004/7004  
OPTION CUSTOMER POWER/SIGNAL  
PROFINET, IRB2600/4600/6xx0/7600

Status: APPROVED  
Document no. 3HAC043574-001  
Rev. Ind 07  
Page 22  
Next  
Total 23

Plant: =  
Location: +  
Sublocation: +